

**FULGOR**

MILANO

RANGEHOOD - 40CM  
Wall Mounted

MODEL RC40



**A**

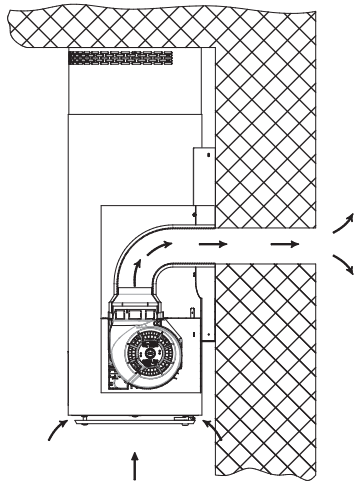

1X



2X



X =  $\begin{cases} 1 \times \phi 150 \\ \text{O} \\ 1 \times \phi 120 \end{cases}$

**B**

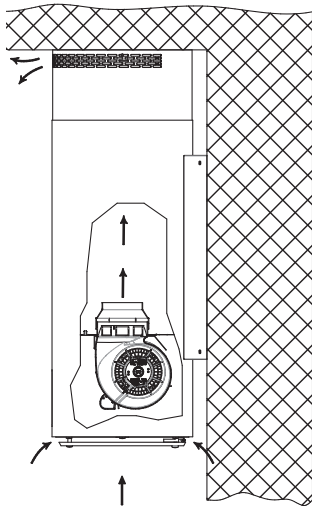

2X

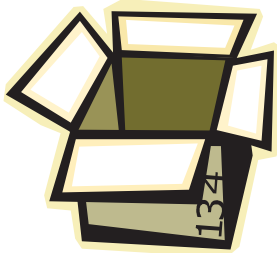

N.1 RIDUZIONE  $\phi 150 \times \phi 120$

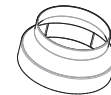

N.1 STAFFA A SOFFITTO



N.1 COPERTURA

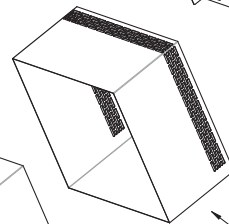

N.6 VITI AUTOF.  $\phi 4.8 \times 38$



N.1 VETRO PERIMETRALE

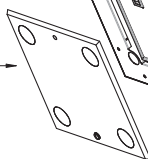

N.1 DISTANZIALE NJLON



N.1 VITE POELIERS M6 x 40

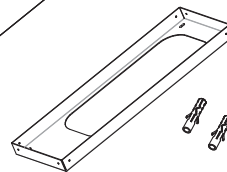

N.6 TASSELLI  $\phi 8$



N.6 RONDELLE  $\phi 18 \times \phi 6$



**Dear Customer,**

we would like to thank you and congratulate you on your choice.

This new product has been carefully designed and built using top quality materials, and meticulously tested to ensure that it meets all your culinary requirements.

Please read and observe these simple instructions, which will enable you to achieve excellent results from the very first time you use it. This state-of-the-art appliance comes to you with our very best wishes.

## **THE MANUFACTURER**

**THIS PRODUCT IS DESIGNED FOR DOMESTIC USE.**

**THE MANUFACTURER DECLINES ALL RESPONSIBILITY FOR DAMAGES TO THINGS OR PEOPLE DERIVING FROM INCORRECT INSTALLATION OR IMPROPER, ERRONEOUS OR UNSUITABLE USE.**

**THE APPLIANCE MUST NOT BE USED BY PEOPLE (INCLUDING CHILDREN) WITH PHYSICAL, SENSORIAL OR MENTAL IMPAIRMENTS, OR BY PEOPLE WITHOUT THE NECESSARY EXPERIENCE**

**OR KNOWLEDGE, UNLESS THEY ARE SUPERVISED OR INSTRUCTED IN THE USE OF THE APPLIANCE BY A PERSON RESPONSIBLE FOR THEIR SAFETY.**

**CHILDREN MUST BE SUPERVISED TO ENSURE THAT THEY DO NOT PLAY WITH THE APPLIANCE.**

**We recommend that you wear gloves during installation and maintenance.**

When installing an extracting version (the extracted air is sent outside = Fig. A), it is important to:

- prepare an air exhaust hole and duct with a diameter of 150 mm.
- use a duct that is as short as possible
- use a duct with the least number of curves possible (maximum curve angle 90°)
- avoid the use of flat ducts and ducts of different section as much as possible
- use a duct with the smoothest possible interior and conforming to the standard
- do not connect the hood to a duct that exhausts fumes produced by combustion (fireplaces, boilers, ovens, etc.)
- do not discharge the air into a cavity in the wall unless the cavity has been prepared for that purpose.
- provide the room with air intakes so that the hood does not create negative suction (no higher than 0.04 mbar).

When installing a filtering version (the extracted air is returned to the kitchen = Fig. B) there is no need to prepare a hole and exhaust duct, but you must provide two activated carbon filters (request them separately as an accessory).

**Fig. 1:** using the fixing bracket (1), mark the positions of the fastening holes on the ceiling.

Fasten using no. 2 anchors  $\varnothing 8$  + no. 2 screws  $\varnothing 4.8 \times 38$  + no. 2 washers.

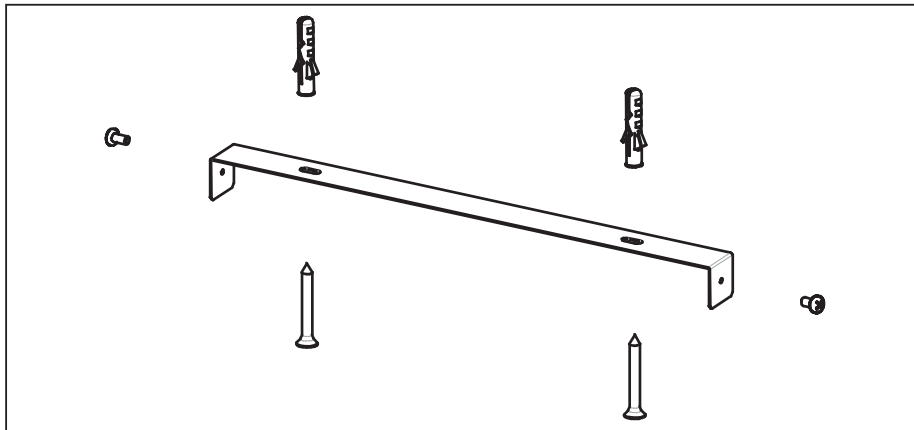

**Fig. 2:** attach the cover with grill (2) to the fixing bracket (1). (If you wish this cover can be omitted in the extracting version).

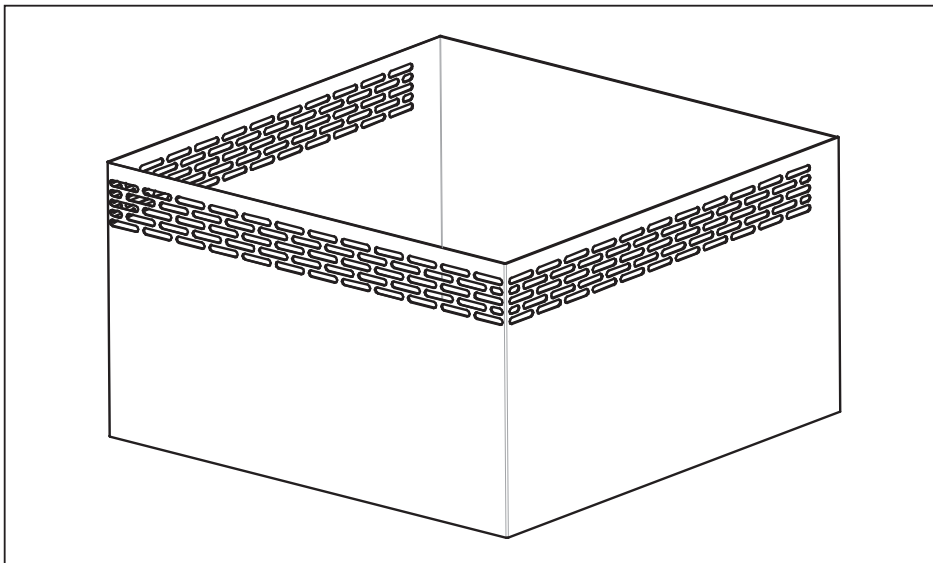

**Fig. 3:** adjust the telescopic excursion of the upper cylinder and fasten it to the bracket (1) using the two M4X12 screws provided.

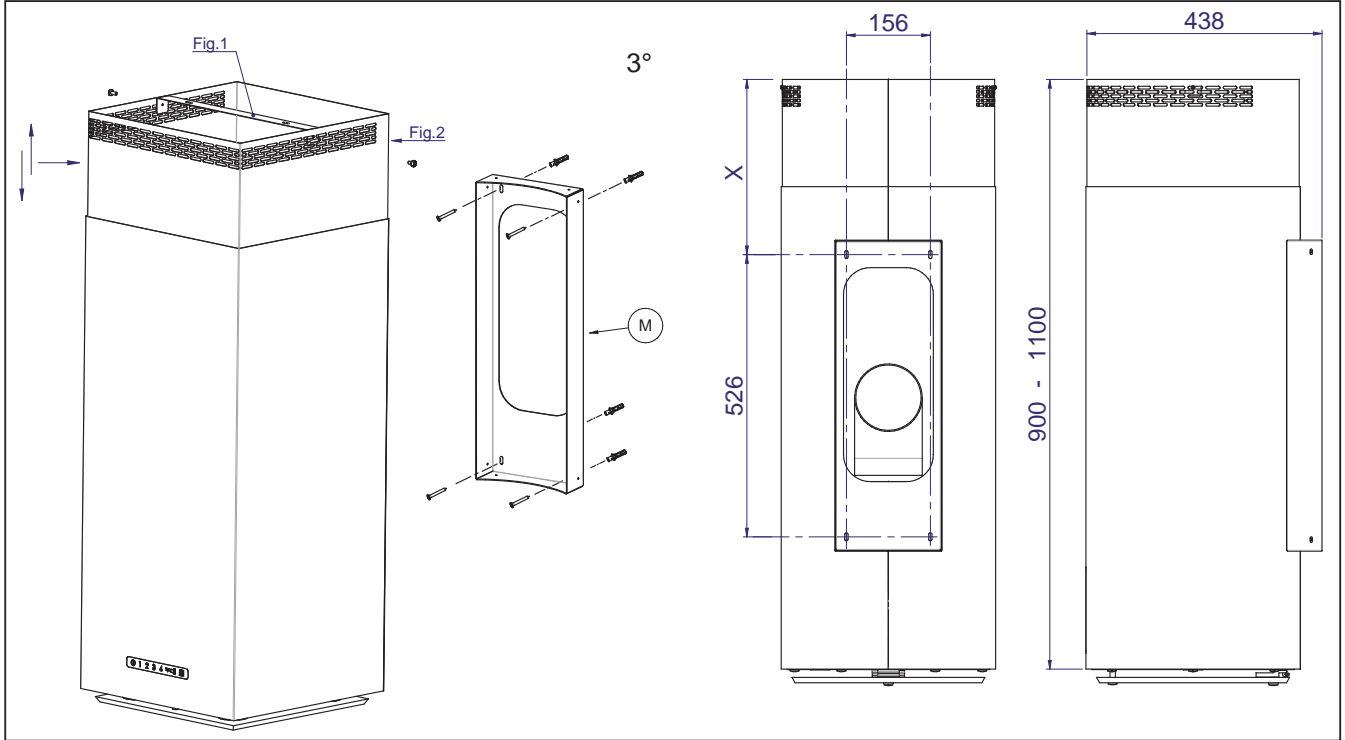

**IMPORTANT:** to fasten the hood to the bracket that has previously been fastened to the wall, see detail (M); if you need to know the height at which the hood must be positioned, see the measurements table.

<b>X = 327 H = 1100</b>
<b>X = 227 H = 1000</b>

The H900 does not need part 2  
 Variable hood height: 900 - 1000 - 1100

**Fig. 4:** mount the grease filter on the hood cylinder with the metal handle.

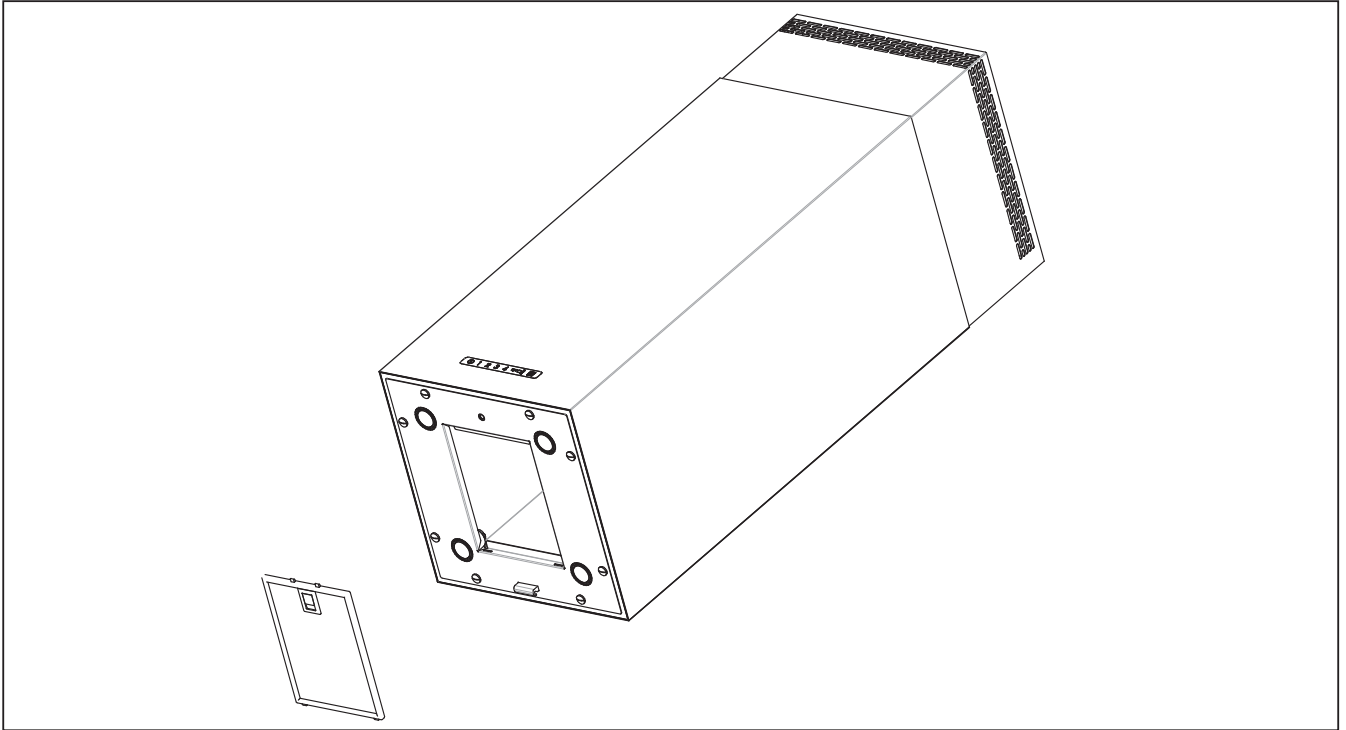

**Fig. 5:** position the glass with the smaller diameter facing down (A).

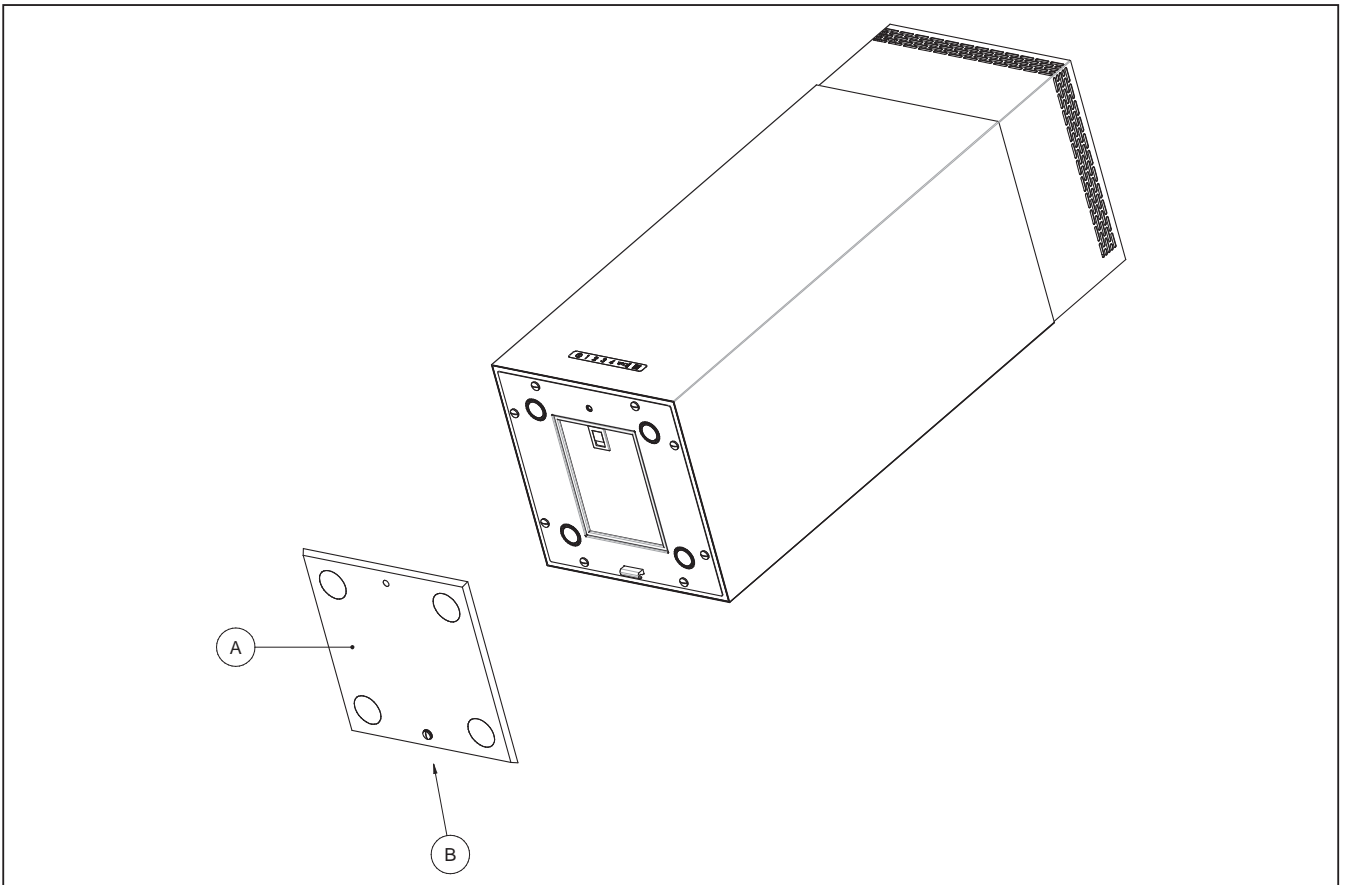

**Fig. 6:** hook the hinge (B) integrated into the glass to the hook of the male hinge C.

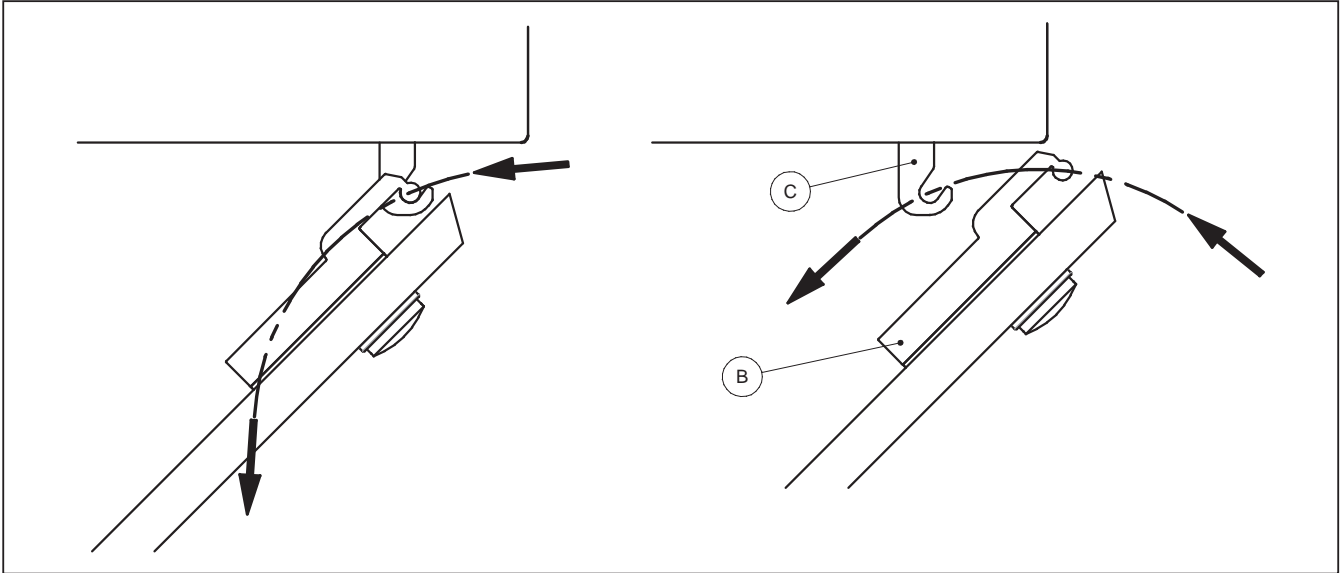

**Fig. 7:** slide the H26 Nylon spacer on the M6X40 screw provided and fasten it, by passing through the hole in the hole in the glass, to the upper hole in the hood cylinder, tightening it by hand or using a tool or coin.

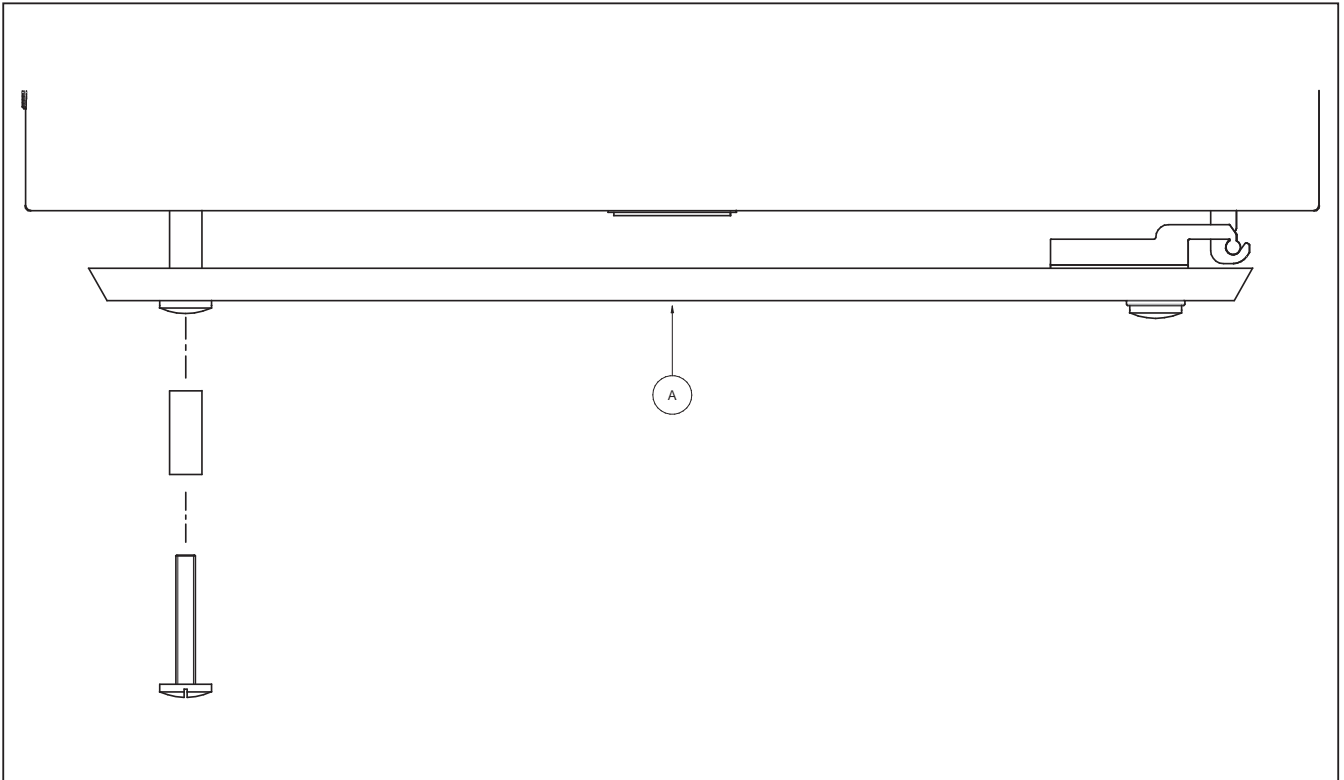

**Fig. 8:** if a filtering hood is being installed, you must request two carbon filters (D) (supplied as a separate accessory). Proceed to the insertion of the drawer-type carbon filter with the required type of slot system.

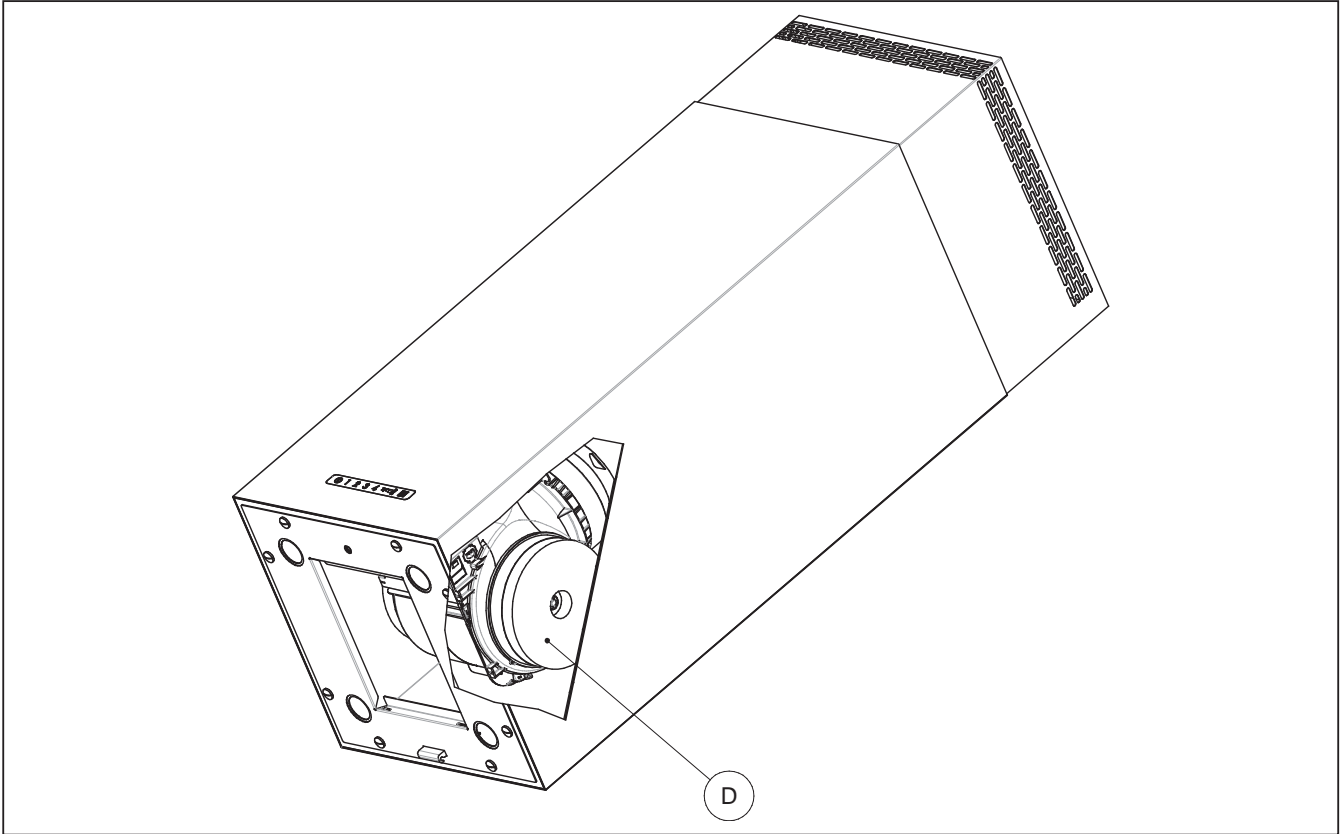

## CONTROLS

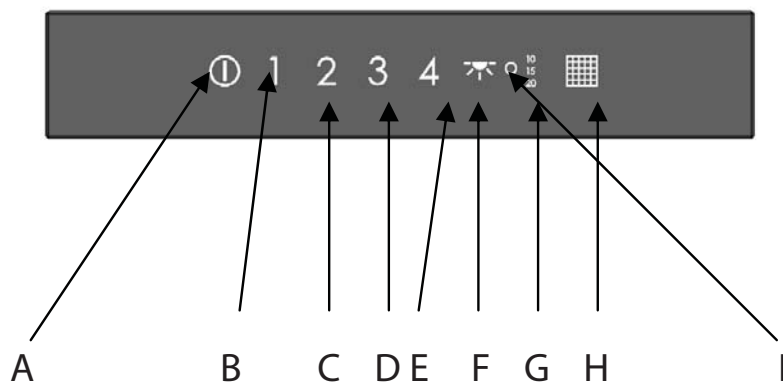

- A) starts/stops the motor at the second speed (the intermediate operating speed)
- B) selects the first motor speed
- C) selects the second motor speed
- D) selects the third motor speed
- E) selects the fourth motor speed
- F) turns on the halogen lamp: if held down, you can select 3 different levels of light. The last level selected is remembered for the next time it is turned on.  
If the product has an LED, it is not possible to adjust the intensity and, for this reason, it only has an on/off function
- G) turns on the timer (delayed turn-off): you can choose from 3 times (10', 15', 20')
- H) \*Filter alarm (see detail)
- I) remote-control receiver sensor



### \*Filter alarm:

the first thing to do after inserting the plug is to set the hood to extracting or filtering mode; proceed as follows:

when the plug is inserted, all the lights turn on for several seconds: in this state, press the on/off button for about 8 seconds until the H LED lights. Then press B if you want the hood to operate in extraction mode (in this mode, the carbon filter count is not considered because there is no filter); the red LED of the H filter light flashes and you confirm the selection by pressing it. To set the hood to filtering mode (and, thus, with counts for both the grease filters and the carbon filters), about 8 seconds after turning it on, press C and the red light of the H filter hood will turn steady on; press it to confirm.

After 30 hours of operation, the H button will turn steady on: this means that it is time to remove and clean the grease filters. If the hood is in filtering mode, after 140 hours of operation, the H button will flash: this means that it is time to replace the carbon filters. To reset the count, press the H button for 7-8 seconds.

The filter hour count cannot be reset until the system turns on one of the alarms. So it is not possible to perform intermediate resets.

### OPERATION OF THE REMOTE CONTROL (if provided)

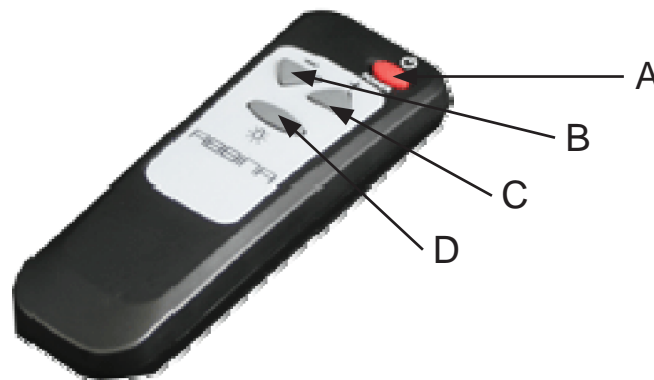

- A) Turns the hood on/off at the second speed
- B) Decreases the speed of the motor
- C) Increases the speed of the motor
- D) Turns the lights on/off. (The intensity can only be regulated manually directly on the hood)

### MAINTENANCE

Turn off the electricity before performing any maintenance or cleaning!

#### Cleaning the hood:

clean the hood at least once every 2 months to avoid the risk of fire; to clean the external body, use a cloth wet with warm water and a neutral detergent for painted hoods and products specifically made for steel for steel hoods. To clean inside the hood, use a cloth wet with denatured alcohol.

Do not use abrasive or corrosive products!

#### Cleaning the grease filters (on both the extracting and filtering hood versions)

clean the grease filters at least once every 2 months to avoid the risk of fire (however, the frequency of cleaning depends on how intensely you use the hood).

To remove the grease filter, use the handle on the filter.

Wash with neutral detergent by hand or in the dishwasher. Keep in mind that washing in the dishwasher could discolour/ darken the filters without, however, reducing their effectiveness.

#### Replacing the carbon filters (filtering version only):

replace the activated carbon filters at least once every 6 months to avoid the risk of fire (however, the frequency of cleaning depends on the intensity with which you use the hood).

### Replacement of bulbs:



Delicately remove the glass bulb cover with a screwdriver.

Replace the bulb with the same type, taking care not to touch the new bulb with your bare hands to void damaging it.  
Do not touch the bulb if it is still hot!

### OPERATING PROBLEMS

Before calling for service, check these simple things:

#### **Why is the hood not working?**

- has the electricity been interrupted?
- was the hood on?
- is the power plug disconnected and/or damaged?

#### **Why is the hood working poorly?**

- was the hood turned on at a sufficient speed to extract the fumes and vapours generated?
- is the kitchen sufficiently ventilated to allow for good air intake?
- do the grease filters need to be cleaned?
- do the carbon filters need to be replaced (in the case of a filtering hood)?
- after 10 minutes of uninterrupted operation at the fourth speed, the hood automatically goes to the second speed unless a timer was activated (energy savings).

#### **Why did the hood suddenly turn off?**

- was there a sudden interruption of the current?
- is the power plug disconnected and/or damaged?
- after 5 hours of uninterrupted operation, the hood automatically turns off (energy savings)

This warranty is provided by:

**Name:** Fulgor Milano Australasia Pty Ltd ACN 164 163 982  
**Address:** 14/24-32 Lexington Drive, Bella Vista  
**Telephone Number:** 1300 FULGOR (1300 385 467)  
**Email Address:** contact@fulgor.com.au  
**Website:** www.fulgor.com.au

This Warranty is provided for the following Product: (please fill in details upon purchase)

**Product Name:** \_\_\_\_\_

\_\_\_\_\_

**Model Number:** \_\_\_\_\_

\_\_\_\_\_

**Date of Purchase:** \_\_\_\_\_

## 1. Warranty Period

### 1.1 Domestic Warranty

Fulgor Milano Australasia warrants that any Product purchased from it, and when used in accordance with the Instructions for household or personal use, shall be delivered free from defects in workmanship and materials and will perform for a period of two (2) years from the date of purchase.

### 1.2 Commercial Warranty

Fulgor Milano Australasia warrants that any Product purchased from it, and when used in accordance with the Instructions for Commercial Use, shall be delivered free from defects in workmanship and materials and will perform for a period of one (1) year from the date of purchase.

## 2. Exclusions from Warranty

### 2.1 This Warranty does not cover:

- i. Abuse;
- ii. Misuse;
- iii. Any damage sustained by a product whilst being transported;
- iv. Other defects not related to materials or workmanship;
- v. Consumable items including, but not limited to, replacement of light globes, glass breakage due to impact;
- vi. Damage or failure caused to the Product by unsuitable physical or operating environment.

## 3. Warranty Claim

### 3.1 To make a Claim you must:

- a) Contact your nearest Local Servicing Agent, details of which are on Fulgor Milano Australasia's website listed above; and
- b) Provide Proof of Purchase and this Warranty to the Local Servicing Agent.

**3.2** Upon receipt of a valid Claim, a Local Servicing Agent will attend your premises to inspect the Product.

**3.3** Where a Product is found to be defective, Fulgor Milano Australasia will, at its option and expense, repair or replace the Product or the defective material or part. If Fulgor Milano Australasia repairs or replaces a defective Product, the warranty period for any Product repaired or replaced does not extend beyond the original Warranty Period.

**3.4** Where the Product is located outside the Normal Servicing Area, You must pay for the cost of the nearest Local Servicing Agent to attend your premises.

- 3.5** If You are unable to provide Proof of Purchase, Fulgor Milano Australasia will not be obliged to repair or replace the defective Product.
- 3.6** Fulgor Milano Australasia will not be responsible for any costs or expenses, loss or damage, associated with:
- a) Any transport of the Product to a Local Servicing Agent;
  - b) Any consequential damages from the use of the Product;
  - c) The de-installation and re-installation of the Product at Your premises to make the Product available for inspection and servicing/repair, or any consequential damage caused by de-installation and re-installation of the Product.
- 3.7** You may assign this Warranty. An assignee of this Warranty may only make a Claim where the following conditions are met:
- a) You have provided to the assignee, and the assignee produces, Your Proof of Purchase; and
  - b) Any claim by an assignee is made within the original Warranty Period.

#### **4. Statutory and Other Legal Rights**

- 4.1.** Your rights under this Warranty are in addition to and do not affect in any way any other rights or remedies that you have under any law which relates to the Product.
- 4.2.** Our goods come with guarantees that cannot be excluded under the Australian Consumer Law. You are entitled to a replacement or refund for a major failure and compensation for any other reasonably foreseeable loss or damage. You are also entitled to have the goods repaired or replaced if the goods fail to be of acceptable quality and the failure does not amount to a major failure.

#### **5. Definitions**

**"Claim"** means a claim made under this Warranty.

**"Commercial Use"** means use that is not household or personal use;

**"Fulgor Milano Australasia"** means Fulgor Milano Australasia Pty Ltd ACN 164 163 982;

**"Instructions"** means any instructions provided by Fulgor Milano Australasia for the use of the Product;

**"Local Servicing Agent"** means a servicing agent which has been appointed by Fulgor Milano Australasia, to service a Product;

**"Normal Servicing Area"** means an area where a Local Servicing Agent has been appointed by Fulgor Milano Australasia to service Products;

**"Product"** means the product of Fulgor Milano Australasia that this Warranty applies to;

**"Proof of Purchase"** means the receipt issued to You at the point of sale;

**"Warranty"** means this warranty statement;

**"Warranty Period"** means the applicable warranty period depending on whether it is commercial warranty or domestic warranty;

**"You"** means you the purchaser of the Fulgor Milano Australasia Product.