

FULGOR

MILANO

STORAGE DRAWER 15cm

MODEL WD15-20

Dear Customer,

we would like to thank you and congratulate you on your choice.

This new product has been carefully designed and built using top quality materials, and meticulously tested to ensure that it meets all your culinary requirements.

Please read and observe these simple instructions, which will enable you to achieve excellent results from the very first time you use it. This state-of-the-art appliance comes to you with our very best wishes.

THE MANUFACTURER

THIS PRODUCT IS DESIGNED FOR DOMESTIC USE. THIS APPLIANCE IS INTENDED FOR DOMESTIC AND SIMILAR USE, SUCH AS:

- IN THE STAFF KITCHEN AREAS OF STORES, OFFICES AND OTHER WORKPLACES;
- IN FARMHOUSES;
- FOR USE BY HOTEL AND MOTEL GUESTS AND OTHER PROFESSIONAL ENVIRONMENTS;
- IN BED-AND-BREAKFASTS.

THE MANUFACTURER DECLINES ALL RESPONSIBILITY FOR DAMAGES TO THINGS OR PEOPLE DERIVING FROM INCORRECT INSTALLATION OR IMPROPER, ERRONEOUS OR

UNSUITABLE USE.

THE APPLIANCE MUST NOT BE USED BY PEOPLE (INCLUDING CHILDREN) WITH PHYSICAL, SENSORIAL OR MENTAL IMPAIRMENTS, OR BY PEOPLE WITHOUT THE NECESSARY EXPERIENCE OR KNOWLEDGE, UNLESS THEY ARE SUPERVISED OR INSTRUCTED IN THE USE OF THE APPLIANCE BY A PERSON RESPONSIBLE FOR THEIR SAFETY. CHILDREN MUST BE SUPERVISED TO ENSURE THAT THEY DO NOT PLAY WITH THE APPLIANCE.

Table of Contents

1. PRECAUTIONS
2. INSTRUCTIONS FOR RECYCLING -
PROTECTION OF THE ENVIRONMENT
3. SAFETY INSTRUCTIONS
4. APPLIANCE DESCRIPTION
5. BEFORE YOU BEGIN
6. USING YOUR WARMING DRAWER
7. APPLIANCE INSTALLATION



CONSUMER INSTRUCTIONS: Includes recommendations for use, description of commands and correct procedures for the care and clearing of the appliance.



INSTALLATION INSTRUCTIONS: Use intended for qualified technicians.

1. PRECAUTIONS

This manual is an integral part of the appliance. Take care of it and keep it within reach for the entire life of the object-holder drawer.

Read these instructions before installing and using the appliance. Installation should be performed by qualified personnel only, in conformity with current law. This appliance is intended for domestic use only in conformity with current EEC directives. The manufacturer will not be held liable in the event of a failure to follow THESE WARNINGS AND SAFETY INSTRUCTIONS. KEEP THESE INSTRUCTIONS WITH THE APPLIANCE. IF THE APPLIANCE SHOULD BE GIVEN TO ANOTHER PERSON MAKE SURE THESE INSTRUCTIONS ARE SUPPLIED WITH IT.

DO NOT DISPOSE OF MATERIALS IN THE HOME. SORT THE VARIOUS MATERIALS BY CLASSIFICATION AND DISPOSE OF THEM PROPERLY.

THE IDENTIFICATION PLATE BEARING THE TECHNICAL DATA, SERIAL NUMBER AND BRAND IS LOCATED IN A PROMINENT POSITION AT THE BOTTOM OF THE EXTRACTABLE DRAWER. NEVER REMOVE THE DATA LABEL.

WARNING! NEVER USE SHARP METAL OBJECTS OR ABRASIVE SCRUBBING PADS THAT COULD CAUSE DAMAGE TO THE SURFACE OF THE APPLIANCE. IF NECESSARY, USE STANDARD NON-ABRASIVE UTENSILS MADE OF WOOD OR PLASTIC.

2. INSTRUCTIONS FOR RECYCLING

- PROTECTION OF THE ENVIRONMENT

Our products are made solely from non-polluting materials that do not harm the environment and are recyclable. We ask for your effort and collaboration in disposing of the packaging in a proper manner. Contact the product retailer or local organizations for further information on recycling. Dispose of the packaging properly. Parts of the package especially plastic, pose a risk for children.

Your old appliance must also be disposed of properly.

Important: consign the appliance to the proper local organization authorized to collect broken appliances. Proper and intelligent disposal consists of recovering materials of value.

3 SAFETY INSTRUCTIONS

THIS APPLIANCE IS INTENDED FOR DOMESTIC USE ONLY! FOLLOW THESE INSTRUCTIONS TO AVOID DAMAGING THE APPLIANCE OR CREATING DANGEROUS SITUATIONS:

- Do not lean or sit on the warming drawer when opened, this could cause damage to the telescopic guide. The maximum carrying weight of the warming drawer is 10kg.

CLEANING:

- Never use a vacuum cleaner. The vacuum may also damage the surface and the components of the appliance: damages for which the manufacturer will not be liable.

- For cleaning the appliance we recommend following the suggestions listed under "Cleaning and Maintenance" of the manual.

REPAIRS:

- **ATTENTION!** Maintenance work and/or repairs must be performed exclusively by specialized personnel. Incorrect installation and maintenance can cause personal injury to the consumer for which the manufacturer will not be liable.

- **ATTENTION!** During the warranty period, the appliance may only be serviced by technicians authorized by the manufacturer or the warranty will be void.

- **WARNINGS!** The manufacturer will not be liable for injury or property damage caused by a failure to follow the above rules or caused by tampering with even part of the appliance and the use of non-original spare parts.

4. INSTRUCTIONS FOR THE CONSUMER

4.0 OPENING OF THE DRAWER

To open the drawer press the front of the drawer



(fig. A)

Grasp the handle



(fig. B),

Pull the drawer



(fig. C)

towards you until it is opened completely.

4.1 CLOSING THE DRAWER

To close the drawer, gently push the drawer back, pushing the front until it has completely gone back. Release the handle.

5. BEFORE YOU BEGIN



Do not leave parts of the packaging in the home. Separate the remaining packaging materials by category and deliver them to your nearest recycling center.

Before using the appliance for the first time, gently clean it with a moist cloth and dry it completely as described under "Cleaning and Maintenance".

6 CLEANING AND MAINTENANCE

Generally speaking, cleaning is the only form of maintenance necessary.

Warning! Do not use harsh detergents or abrasive products and/or scrubbing pads and sponges and sharp objects as they can stain and damage the appearance of the appliance.

Warning! Never use a vacuum cleaner on the internal parts of the appliance.

6.1 Front

The use of a moist cloth is sufficient when cleaning the appliance. In the event the appliance requires further cleaning, add drops of detergent in the water. Dry the appliance with a dry cloth. The stainless steel front of the object-holder drawer can be cleaned with special cleaners for that purpose. Such products prevent the formation of dirt on the surface of the drawer. Apply a minimal amount of the product on a soft and apply it to the surface of the appliance.

6.2 Inside Space

To clean the inside space use a moist cloth. In the event the appliance requires further cleaning add drops of detergent to the water. Dry the surface with a dry cloth.

7 APPLIANCE INSTALLATION

7.1 Before you begin installation

Open the drawer and remove all accessories and packing materials.

Attention! The front of the drawer may be covered with a protective coating over it. Carefully remove the protection before using the object-holder drawer, starting to detach it from below. Make sure that the drawer is not damaged. Be certain that the drawer closes properly. In case of damage, contact the Service Department.

The object-holder drawer can only be built-in on appliances specified by the manufacturer. The manufacturer does not guarantee the operation of the appliance if materials from a different manufacturer have been used. The manufacturer is not responsible for damage caused by improper use.

7.2 Proceed

Before installing the object-holder drawer and the appliance combined with it, provide a fixed intermediate shelf in the cabinet with the capacity to support both appliances.

The combined appliance is then positioned without further intermediate shelves directly on the built-in object-holder drawer.

For the combined, built-in appliance, absolutely follow the instructions for use and assembly.

The main dimensions for the built-in appliance are indicated in mm and shown on the installation diagram. For installation proceed as follows:

1. place the drawer of the cabinet so that it is well centred and aligned;
2. make sure that the frame perfectly adheres to the cabinet;
3. open the drawer and fasten the housing to the walls of the cabinet with the two screws provided.

WARMING DRAWER DIMENSION DIAGRAM 560 X 595 FOR 450 OVENS

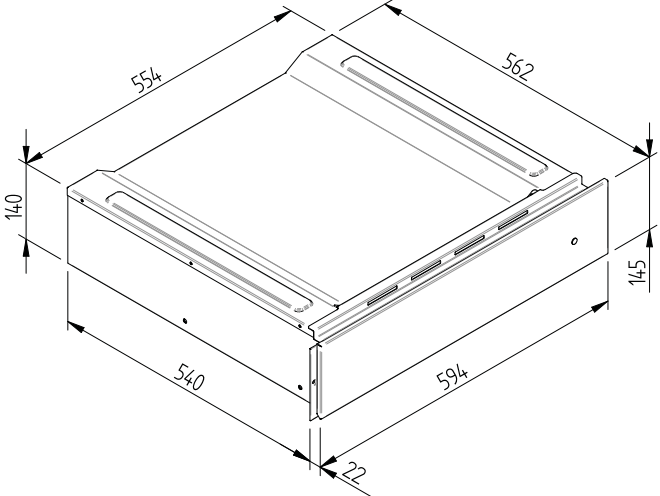
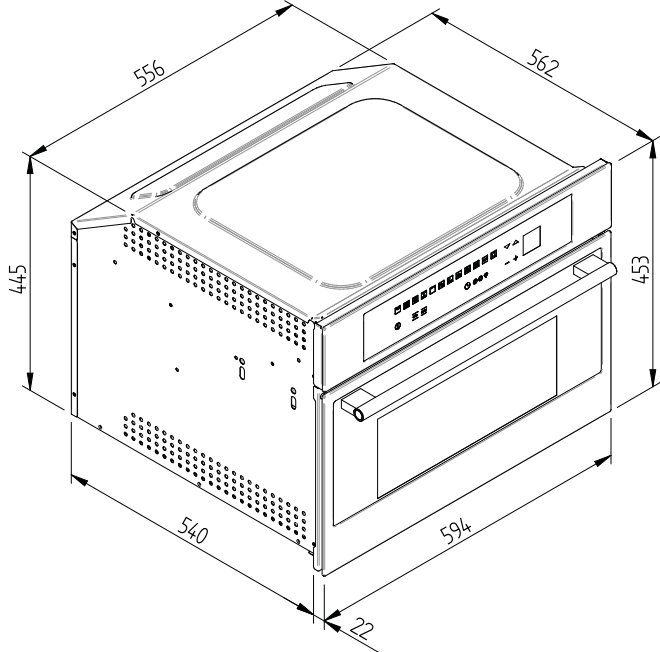
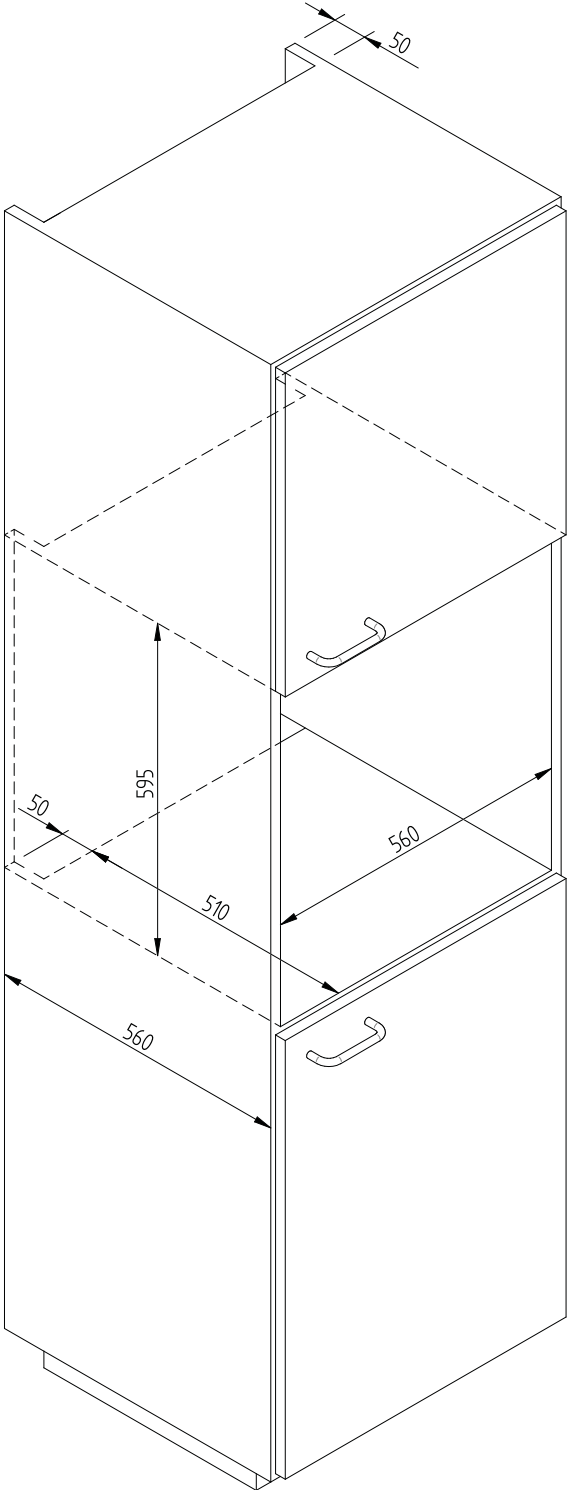

**DIMENSIONAL DIAGRAM DRAWER 145 BUILT-IN 560 X 595
WITH 455 MM WINE CELLAR**

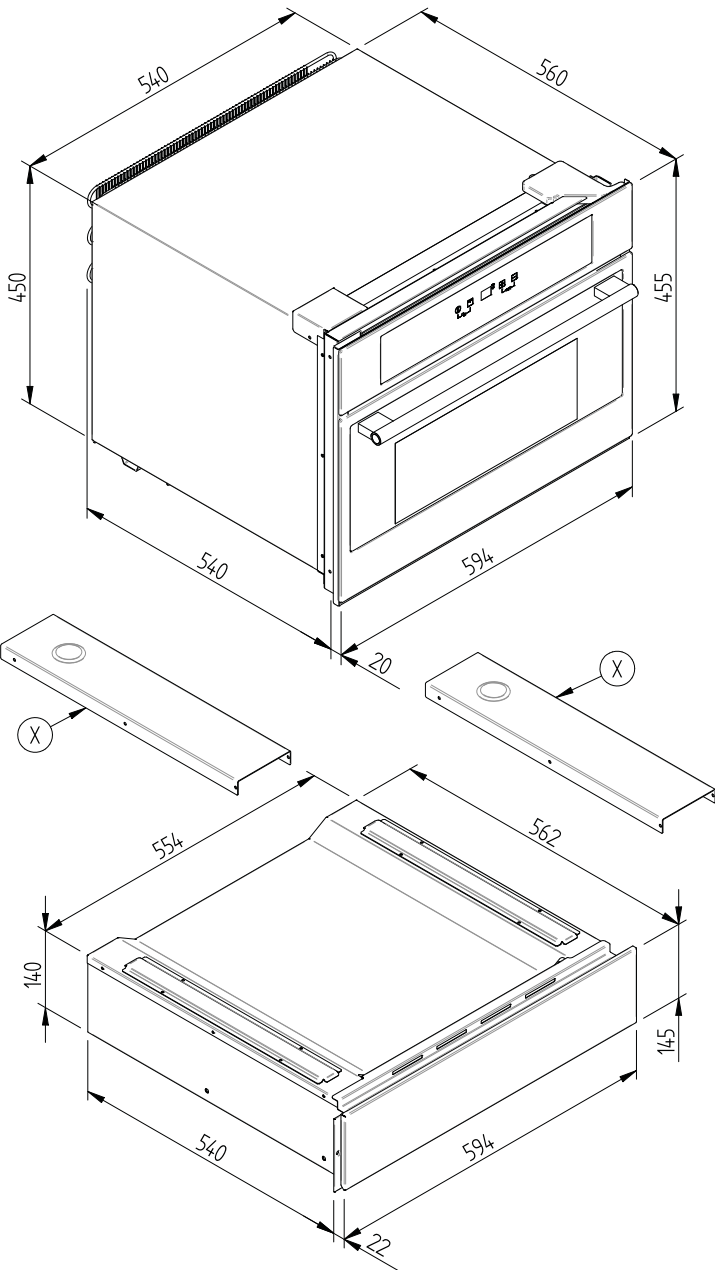
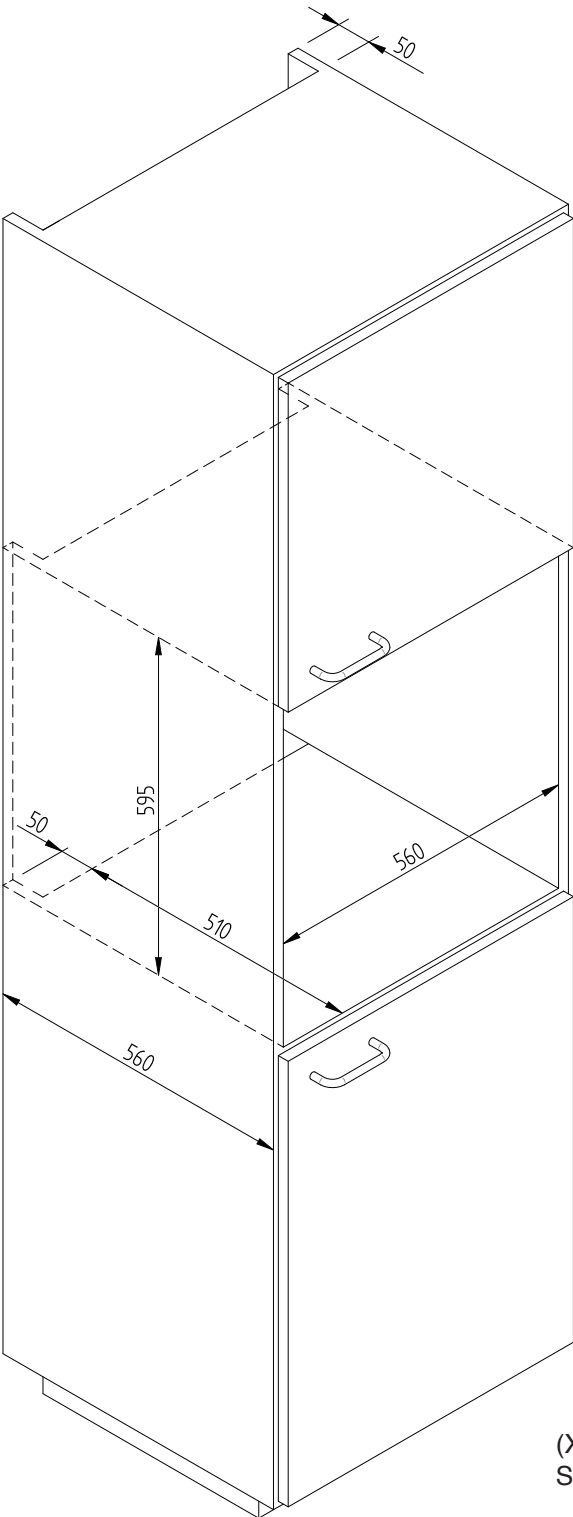

(X) OPTIONAL BRACKETS TO ORDER WHEN THE WOODEN STRIP IS COMBINED WITH THE OBJECT-HOLDER DRAWER

DIMENSIONAL DRAWING DRAWER 145 BUILT-IN 560 X 595 WITH 454 MM COFFEE MACHINE

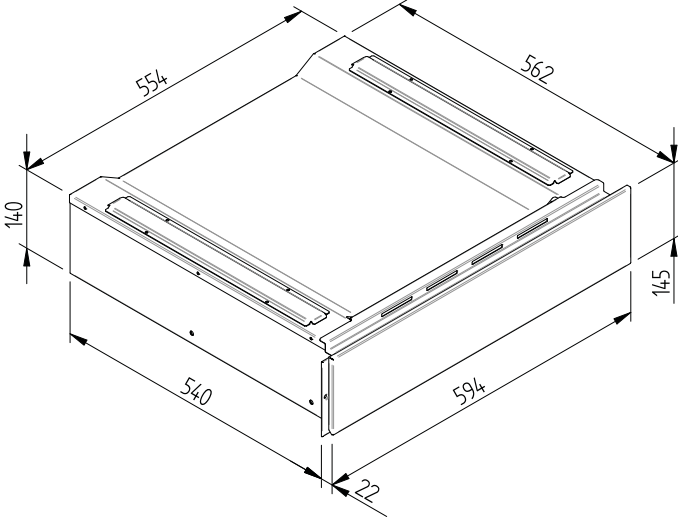
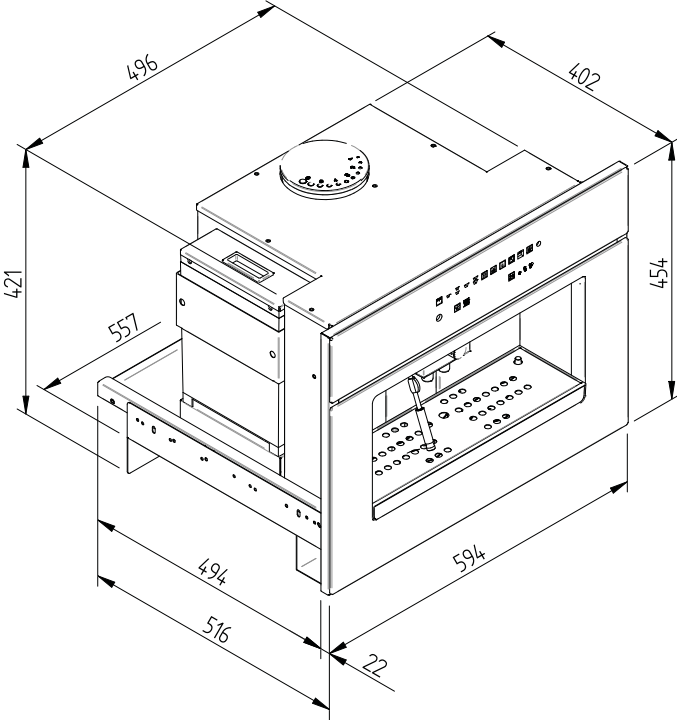
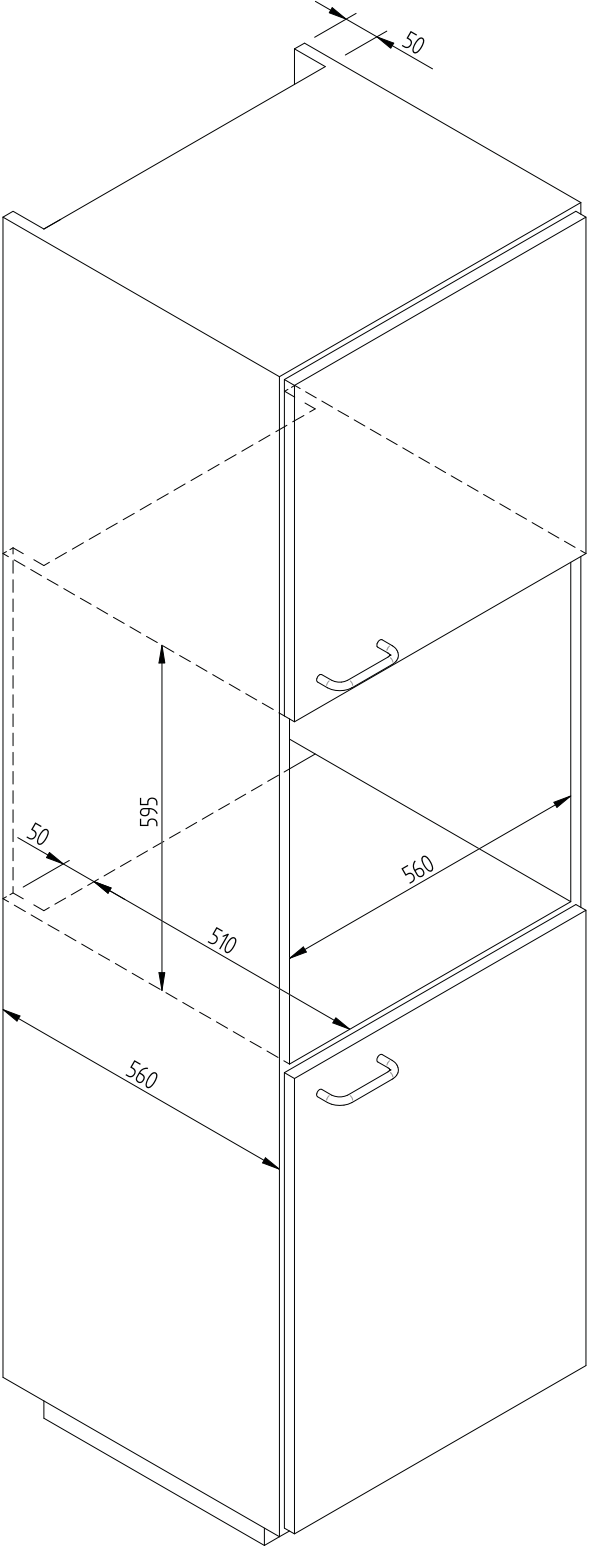

DIMENSIONAL DIAGRAM DRAWER 145 BUILT-IN 560 X 595 WITH 451 MM TV

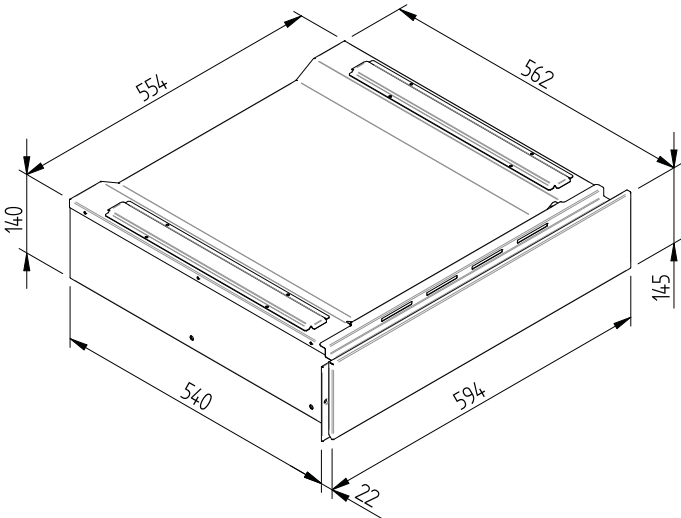
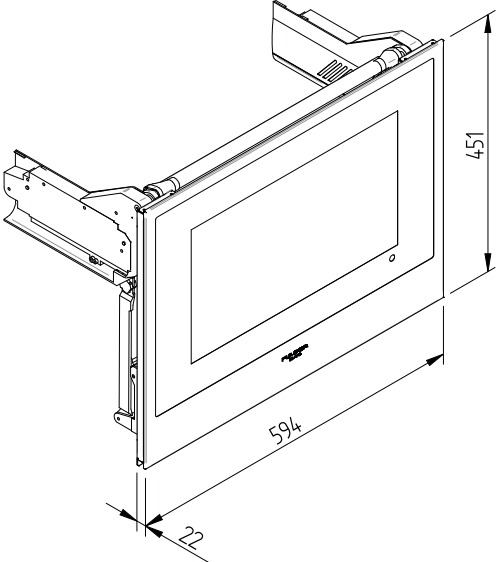
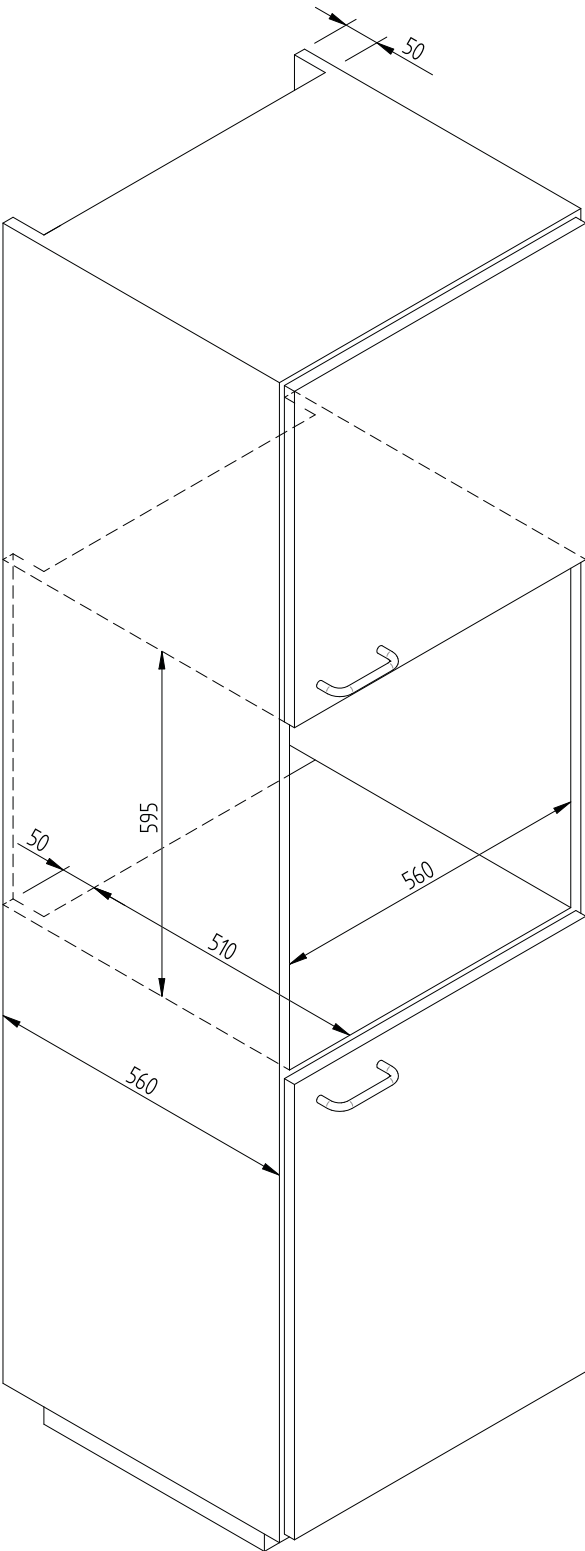

WARNING!

The manufacturer and retailers will not be liable for property damage and personal injury caused by a failure to follow the instructions provided in this manual.

NOTES

NOTES

Name: Fulgor Milano Australasia Pty Ltd ACN 164 163 982
Address: 14/24-32 Lexington Drive, Bella Vista
Telephone Number: 1300 FULGOR (1300 385 467)
Email Address: contact@fulgor.com.au
Website: www.fulgor.com.au

This Warranty is provided for the following Product: (please fill in details upon purchase)

Product Name: _____

Model Number: _____

Date of Purchase: _____

1. Warranty Period

1.1 Domestic Warranty

Fulgor Milano Australasia warrants that any Product purchased from it, and when used in accordance with the Instructions for household or personal use, shall be delivered free from defects in workmanship and materials and will perform for a period of two (2) years from the date of purchase.

1.2 Commercial Warranty

Fulgor Milano Australasia warrants that any Product purchased from it, and when used in accordance with the Instructions for Commercial Use, shall be delivered free from defects in workmanship and materials and will perform for a period of one (1) year from the date of purchase.

2. Exclusions from Warranty

2.1 This Warranty does not cover:

- i. Abuse;
- ii. Misuse;
- iii. Any damage sustained by a product whilst being transported;
- iv. Other defects not related to materials or workmanship;
- v. Consumable items including, but not limited to, replacement of light globes, glass breakage due to impact;
- vi. Damage or failure caused to the Product by unsuitable physical or operating environment.

3. Warranty Claim

3.1 To make a Claim you must:

- a) Contact your nearest Local Servicing Agent, details of which are on Fulgor Milano Australasia's website listed above; and
- b) Provide Proof of Purchase and this Warranty to the Local Servicing Agent.

3.2 Upon receipt of a valid Claim, a Local Servicing Agent will attend your premises to inspect the Product.

3.3 Where a Product is found to be defective, Fulgor Milano Australasia will, at its option and expense, repair or replace the Product or the defective material or part. If Fulgor Milano Australasia repairs or replaces a defective Product, the warranty period for any Product repaired or replaced does not extend beyond the original Warranty Period.

3.4 Where the Product is located outside the Normal Servicing Area, You must pay for the cost of the nearest Local Servicing Agent to attend your premises.

- 3.5** If You are unable to provide Proof of Purchase, Fulgor Milano Australasia will not be obliged to repair or replace the defective Product.
- 3.6** Fulgor Milano Australasia will not be responsible for any costs or expenses, loss or damage, associated with:
- a) Any transport of the Product to a Local Servicing Agent;
 - b) Any consequential damages from the use of the Product;
 - c) The de-installation and re-installation of the Product at Your premises to make the Product available for inspection and servicing/repair, or any consequential damage caused by de-installation and re-installation of the Product.
- 3.7** You may assign this Warranty. An assignee of this Warranty may only make a Claim where the following conditions are met:
- a) You have provided to the assignee, and the assignee produces, Your Proof of Purchase; and
 - b) Any claim by an assignee is made within the original Warranty Period.

4. Statutory and Other Legal Rights

- 4.1.** Your rights under this Warranty are in addition to and do not affect in any way any other rights or remedies that you have under any law which relates to the Product.
- 4.2.** Our goods come with guarantees that cannot be excluded under the Australian Consumer Law. You are entitled to a replacement or refund for a major failure and compensation for any other reasonably foreseeable loss or damage. You are also entitled to have the goods repaired or replaced if the goods fail to be of acceptable quality and the failure does not amount to a major failure.

5. Definitions

"Claim" means a claim made under this Warranty.

"Commercial Use" means use that is not household or personal use;

"Fulgor Milano Australasia" means Fulgor Milano Australasia Pty Ltd ACN 164 163 982;

"Instructions" means any instructions provided by Fulgor Milano Australasia for the use of the Product;

"Local Servicing Agent" means a servicing agent which has been appointed by Fulgor Milano Australasia, to service a Product;

"Normal Servicing Area" means an area where a Local Servicing Agent has been appointed by Fulgor Milano Australasia to service Products;

"Product" means the product of Fulgor Milano Australasia that this Warranty applies to;

"Proof of Purchase" means the receipt issued to You at the point of sale;

"Warranty" means this warranty statement;

"Warranty Period" means the applicable warranty period depending on whether it is commercial warranty or domestic warranty;

"You" means you the purchaser of the Fulgor Milano Australasia Product.



1300 FULGOR - 1300 385 467 | contact@fulgor.com.au
 14/24-32 Lexington Drive, Bella Vista, New South Wales 2153